

With 45%
less plastic
than standard
9" diffuser

AirTech

9" SL

9" fine
bubbles disc diffuser with
EPDM membrane and
integrated ring

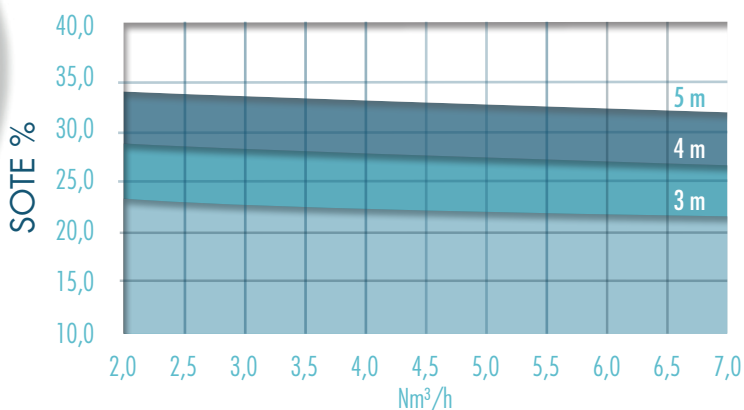

Dimensions

Code	04059
Outer diameter [mm]	257
Threaded connection	3/4" NPT
Weight [Kg]	0,43

Performance

Code	04059
Minimum airflow [Nm³/h]	1,0
Nominal airflow [Nm³/h]	3,5
Maximum airflow [Nm³/h]	7,0
Design airflow range [Nm³/h]	2,0-4,0
* Head losses [cm w.c.]	39,0

* Head losses are calculated at nominal airflow and 4m submergence

Materials

Code	04059
Membrane	EPDM
Holder with integrated retainer ring	PPGF 30%

Cod. 04059

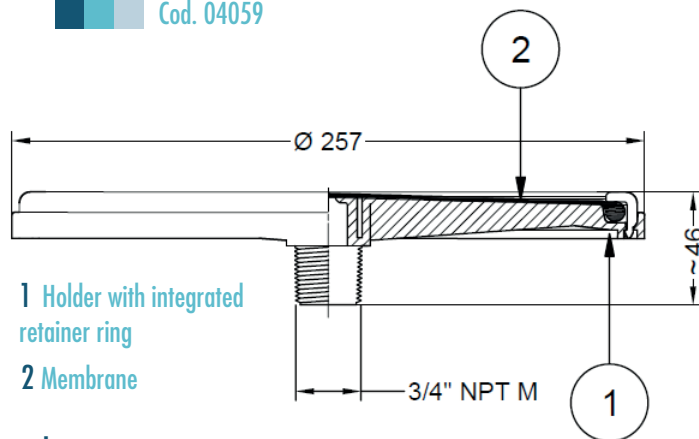

Membrane

Code	04059
Number of slits	>5.000
Perforation [mm]	1,-1,5
Active surface [m²]	0,0381
Average thickness [mm]	2,2
Tensile strength [Kg/cm²]	>122
Elongation at break [%]	450
Hardness [Shore A]	60 ± 5
Plasticizer content [%]	< 15

NOTES

SOTE according to EN 12255-15 (or ANSI/ASCE 2-06)
Tolerances on the thickness ±0,2 mm
Tensile strength according to ISO 37 type 1
Elongation at break ISO 37 type 1