

AirTech 12"

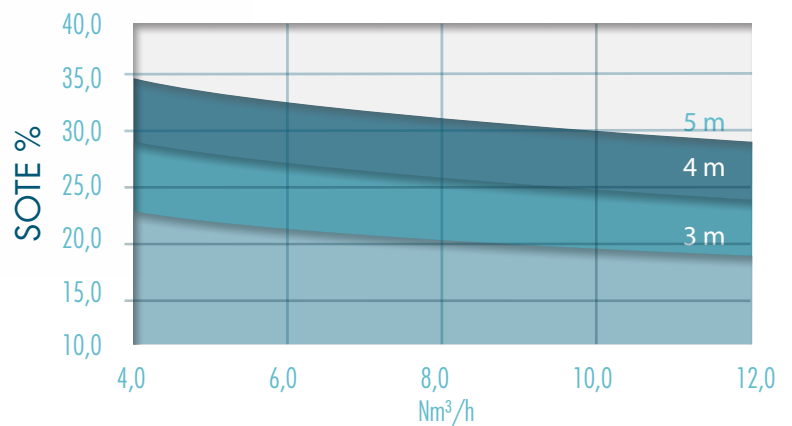

12" fine bubbles
disc diffuser with EPDM/
EPDM+PTFE membrane



Dimensions

Code	04037-04038
Outer diameter [mm]	344
Threaded connection	3/4" NPT
Weight [Kg]	1,03

Performance

Code	04037	04038
Minimum airflow [Nm³/h]	2,0	2,0
Nominal airflow [Nm³/h]	8,0	8,0
Maximum airflow [Nm³/h]	16,0	16,0
Design airflow range [Nm³/h]	3,0-13,0	3,0-13,0
* Head losses [cm w.c.]	36,0	43,0

* Head losses are calculated at nominal airflow and 4m SOTE

Materials

Code	04037	04038
Membrane	EPDM Perox	EPDM Perox+PTFE
Holder	PPGF 30%	PPGF 30%
Retainer ring	PPGF 30%	PPGF 30%

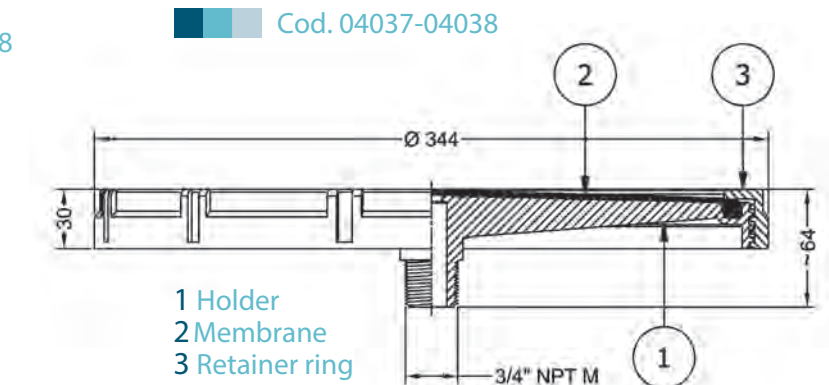

Membrane

Code	04037	04038
Number of slits	>5.200	>5.200
Slit opening [mm]	1,2-2,0	1,2-2,0
Active surface [m²]	0,064	0,064
Average thickness [mm]	2,2	2,3
Tensile strength [Kg/cm²]	>140	>140
Elongation at break [%]	600	600
Hardness [Shore A]	60	60
Plasticizer content [%]	< 10	< 10

NOTES

- SOTE according to EN 12255-15
- Tolerances on the thickness $\pm 0,2$ mm
- Tensile strength according to ISO 37 type 1
- Elongation at break ISO 37 type 1

