

# AirTech 12"

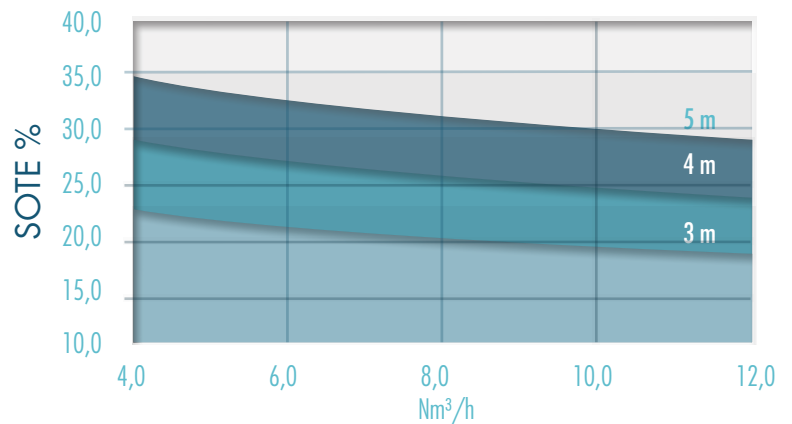

12" fine bubbles  
disc diffuser with EPDM/  
EPDM+PTFE membrane



## Dimensions

Code	04037-04038
Outer diameter [mm]	344
Threaded connection	3/4" NPT
Weight [Kg]	1,03

## Performance

Code	04037	04038
Minimum airflow [Nm³/h]	2,0	2,0
Nominal airflow [Nm³/h]	8,0	8,0
Maximum airflow [Nm³/h]	16,0	16,0
Design airflow range [Nm³/h]	3,0-13,0	3,0-13,0
* Head losses [cm w.c.]	36,0	43,0

\* Head losses are calculated at nominal airflow and 4m submergence

## Materials

Code	04037	04038
Membrane	EPDM Perox	EPDM Perox+PTFE
Holder	PPGF 30%	PPGF 30%
Retainer ring	PPGF 30%	PPGF 30%

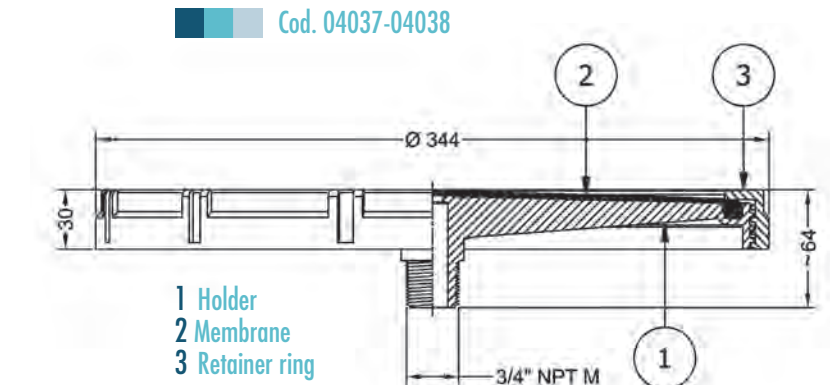

## Membrane

Code	04037	04038
Number of slits	>5.200	>5.200
Perforation [mm]	1,2-2,0	1,2-2,0
Active surface [m²]	0,064	0,064
Average thickness [mm]	2,2	2,3
Tensile strength [Kg/cm²]	>140	>140
Elongation at break [%]	600	600
Hardness [Shore A]	60	60
Plasticizer content [%]	< 10	< 10

## NOTES

SOTE according to EN 12255-15  
Tolerances on the thickness  $\pm 0,2$  mm  
Tensile strenght according to ISO 37 type 1  
Elongation at break ISO 37 type 1

