

# AirTech

5" coarse bubbles  
diffuser with  
EPDM membrane

5"



## Dimensions

Code	04032
Outer diameter [mm]	127
Threaded connection	3/4" NPT
Weight [Kg]	0,09

## Performance

Code	04032
Minimum airflow [Nm <sup>3</sup> /h]	2,0
Nominal airflow [Nm <sup>3</sup> /h]	15,0
Maximum airflow [Nm <sup>3</sup> /h]	30,0
Design airflow range [Nm <sup>3</sup> /h]	10,0-20,0
* Head losses [cm w.c.]	12,4

\* Head losses are calculated at nominal airflow and 4m submergence

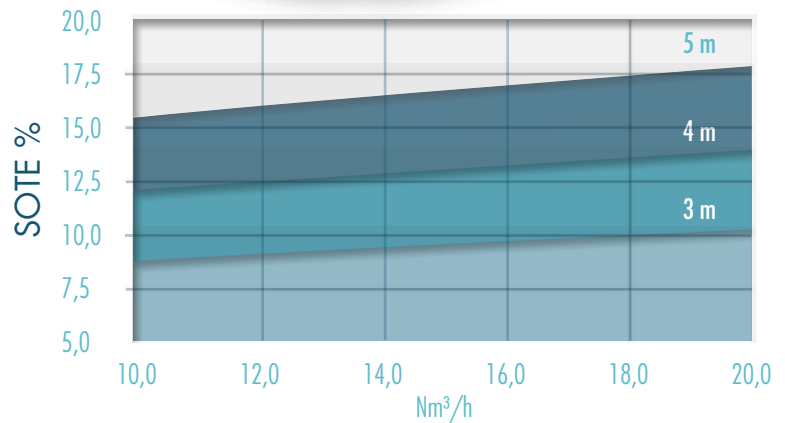

Cod. 04032

## Materials

Code	04032
Membrane	EPDM Perox
Holder	ABS
Retainer ring	ABS

## Membrane

Code	04032
Number of slits	12xØ6
Perforation [mm]	Ø 6
Active surface [m <sup>2</sup> ]	-
Average thickness [mm]	2,30
Tensile strength [Kg/cm <sup>2</sup> ]	>140
Elongation at break [%]	600
Hardness [Shore A]	60
Plasticizer content [%]	<10

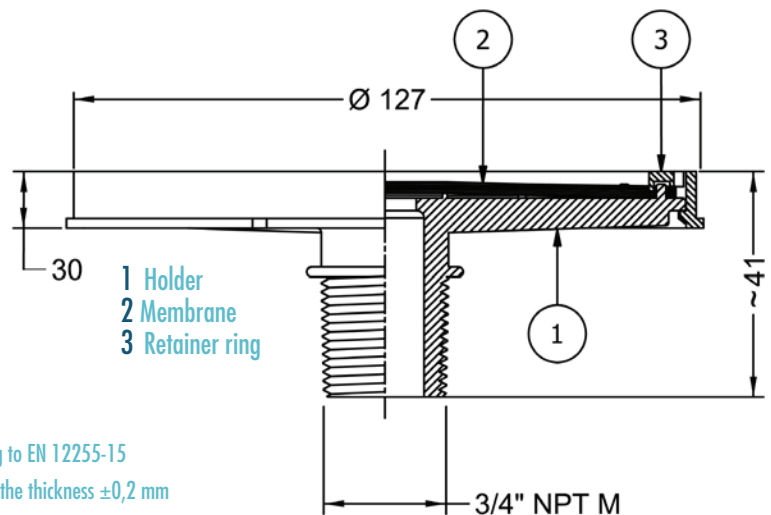

### NOTES

- SOTE according to EN 12255-15
- Tolerances on the thickness ±0,2 mm
- Tensile strength according to ISO 37 type 1
- Elongation at break ISO 37 type 1



WTE SRL. Via Re Depaolini, 52 • 20015 Parabiago (MI) Italy  
Tel. +39 0331 490449 • www.wteitaly.com • wte@wteitaly.com



**SAWAS**  
Water is Life.. Let's Treat

Corporate Address:

AASHRITHA SAWAS SYSTEMS LLP

Plot No.: 8 & 9 B/35, 1st Floor, IDA PHASE #1, PATANCHERU – 502319,  
SANGA REDDY (DT), Tel.: +91 84552 93335,  
www.sawassystems.com | info@sawassystems.com